

ZOD



REFRIGERAZIONE





# Zoe significa vita Zoe means life

Le forme prendono vita nella nuova vetrina FB, che nasce per offrire ai gelatieri e ai pasticceri di tutto il mondo un nuovo prezioso strumento di lavoro. Un design raffinato dove l'essenziale si addolcisce, per lasciare spazio a una elegante convessità.

Forms come to life in the new FB's display cabinet, which comes to life to offer a new precious professional tool for ice-cream makers and pastry chefs from all around the world. A sleek design where the essential softens to make room for an elegant convexity.











# Classe cristallina Crystalline class

Un diamante che risplende in ogni suo lato, anche grazie alla doppia illuminazione al LED. Zoe, la bellezza in tutte le sue sfaccettature.

Zoe is a diamond that shines on every side, also thanks to the double LED lighting. Zoe is beauty in all its aspects.





# In movimento Always moving



Zoe non è solo l'emozione di vivere la bellezza nella sua forma più pura, ma anche un concentrato di tecnologia. Innovazione nella forma, ma anche nel contenuto. Non c'è bene più prezioso del tempo, da dedicare a voi e ai vostri clienti grazie a una soluzione tecnica unica: nessun vetro che si apre verso l'alto o verso il basso ma un semplice meccanismo di scorrimento del tettino, che permette una comoda e veloce pulizia interna.

Zoe is not only the thrill to experience the beauty in its purest form, but also a wealth of technology. It is innovation in form but also in contents. Time is the most valuable asset we have. Now you can devote time to yourself and to your customers thanks to a unique technical solution with no glass that opens upwards or downwards but just a simple sliding canopy, which allows a quick and easy cleaning.

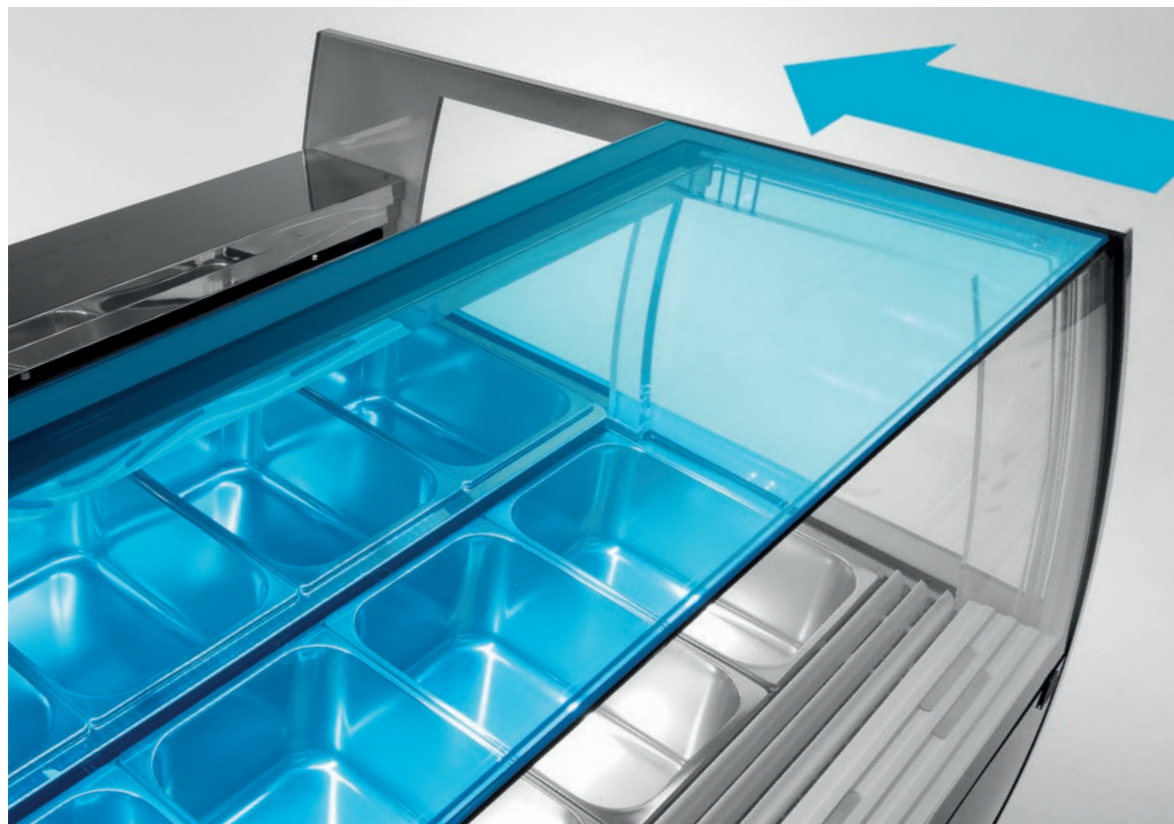





# Senza veli All naked

Trasparenza assoluta per far posto alle vostre magiche creazioni, le vere protagoniste del locale. Zoe è realizzata completamente in vetro extrachiaro. Ogni suo lato, dal tetto no ai fianchi, passando per i vetri e i pannelli frontali.

A complete transparency that makes room for your magical creations: the true stars of your shop. Zoe is entirely made of extra-clear glass. Every single piece, from the canopy to the front and side panels, is made of glass.

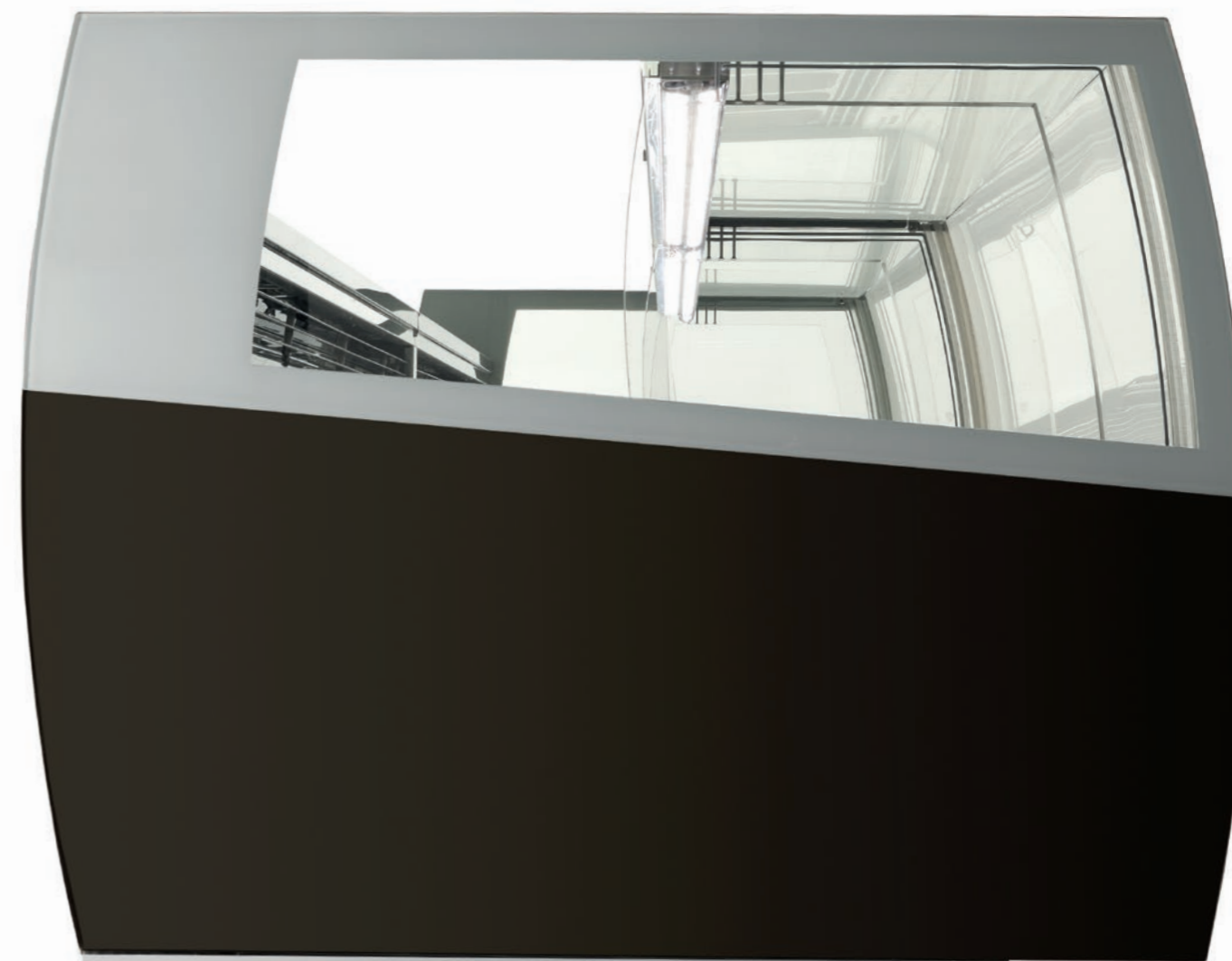







# CARATTERISTICHE TECNICHE E GAMMA PRODOTTI

## TECHNICAL SPECIFICATIONS AND PRODUCT RANGE

### GELATERIA ICE-CREAM

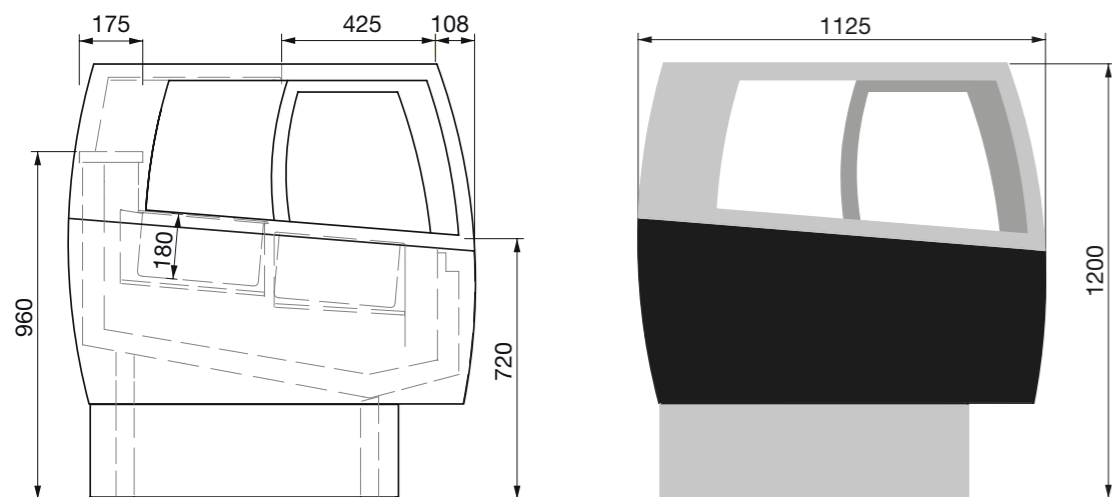

### PASTICCERIA VENTILATA VENTILATED PASTRY

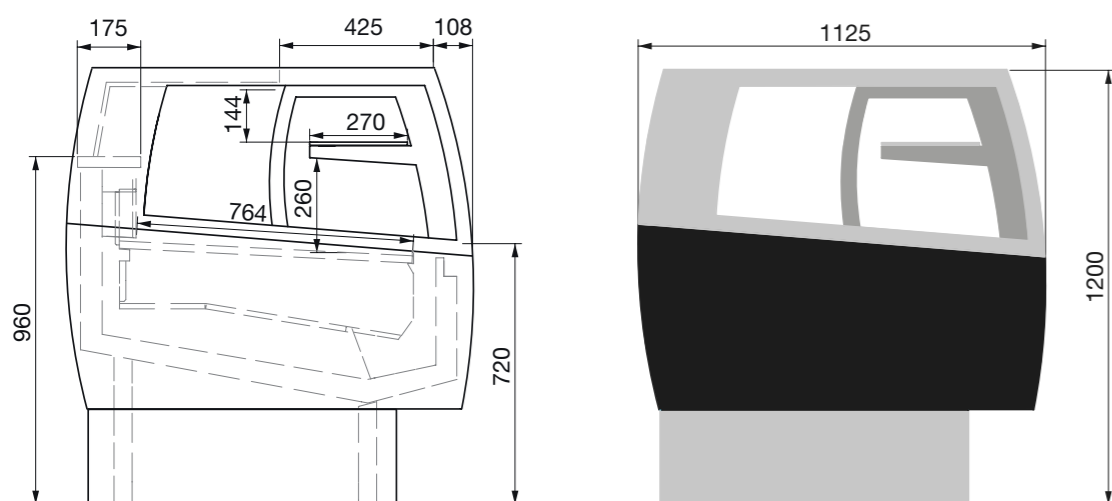

### ALLESTIMENTO VASCHETTE GELATO DISPONIBILI ICE CREAM TUBS

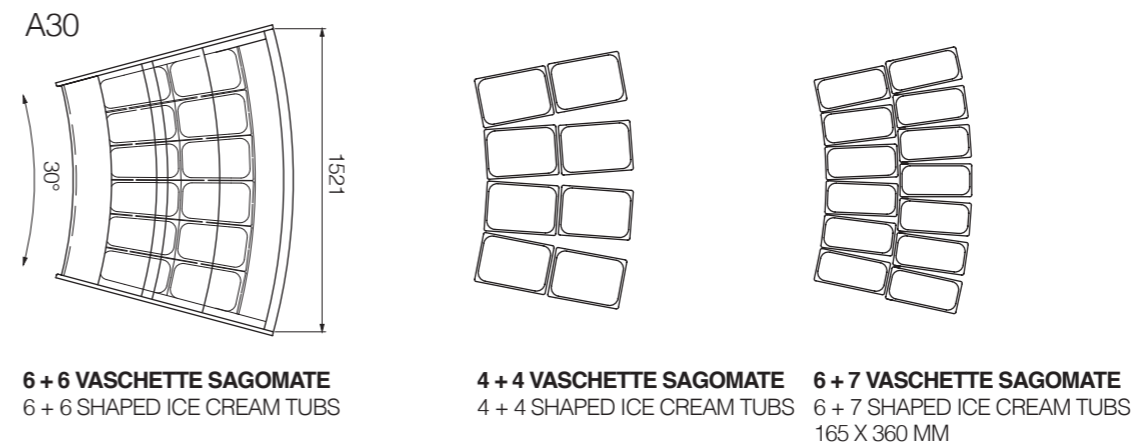
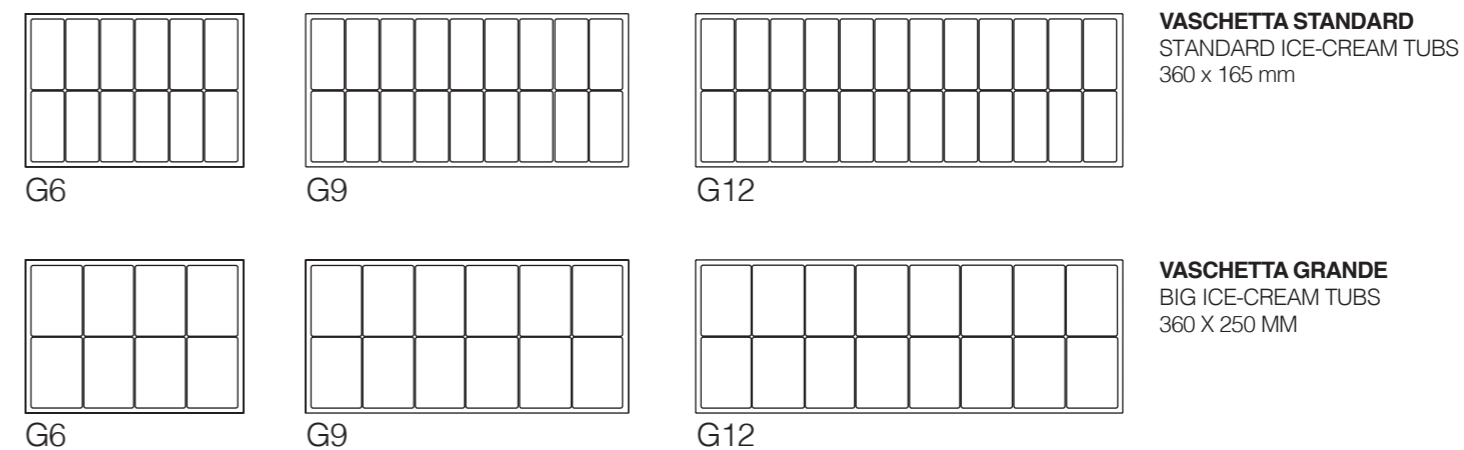

### ESTETICA E STRUTTURA

Cristallo e pannello frontale in vetro extrachiaro senza serigrafie	Front window and panel in extra clear glass with no silkscreens
Tettino in vetro temperato extrachiaro scorrevole	Sliding top made of extra clear tempered glass
Chiusura lato operatore con scorrevoli in plexiglass	Operator's side closing by plexiglass sliding doors
Dispositivo di illuminazione a doppio LED sul tettino e sulla mensola di esposizione	Double LED lighting on top and shelf
Spalle terminali in vetrocamera extrachiaro	End side panels in IGU extra clear glass

### AESTHETIC AND FRAMEWORK

### TECNOLOGIA

Impianto refrigerante standard con compressore semirmeritico 380/3/50 Hz (versione gelato) ed ermetico 230/1/50 Hz (versione pasticceria) su unità condensatrici incorporate ad aria	Standard cooling system with semi-hermetic compressor 380/3/50 Hz on ice cream version and hermetic compressor 230/1/50 Hz on pastry version for incorporated air-cooling condensing units
Pannello di controllo elettronico con termometro e termostato digitali	Electronic check panel with digital thermometer and thermostat
Gas refrigerante R404a	Refrigerating gas R404a

### TECHNOLOGY

### TABELLA DIMENSIONI DISPONIBILI (mm)

#### DIMENSIONAL COMPARATIVE CHART (mm)

GAMMA PRODUCT RANGE	GELATO ICE-CREAM	PASTICCERIA VENTILATA VENTILATED PASTRY	PASTICCERIA VENTILATA CON CASSETTI PASTRY W. VENTILATED REFRIGERATION WITH STORAGE	PASTICCERIA NEUTRA O STATICA NEUTRAL PASTRY OR W. STATIC REFRIGERATION	PRALINE PRALINE	SNACK FREDDO COLD SNACK	SNACK CALDO SECCO DRY-HUMIDE WARMED SNACK
1090 mm (2M/G6)	•	•	•	•	•	•	•
1615 mm (3M/G9)	•	•	•	•	•	•	•
2140 mm (4M/G12)	•	•	•	•	•	•	•
1560 mm (A 30°)	•	•					

**N.B.:** La temperatura di esercizio è riferita a condizioni ambientali di: +30°C/55% UR (classe 4)  
 N.B.: The working temperature refers to the following environmental conditions: +30°C/55% Relative Humidity (class 4)





FB is a trademark of CLABO GROUP S.r.l.  
Viale dell'Industria, 15 | 60035 Jesi (AN) | Italy  
Tel. +39 0731 61531 | Fax +39 0731 6153211  
[www.fbstyle.it](http://www.fbstyle.it) | [info@fbstyle.it](mailto:info@fbstyle.it)